

4

3

2

1

B

B

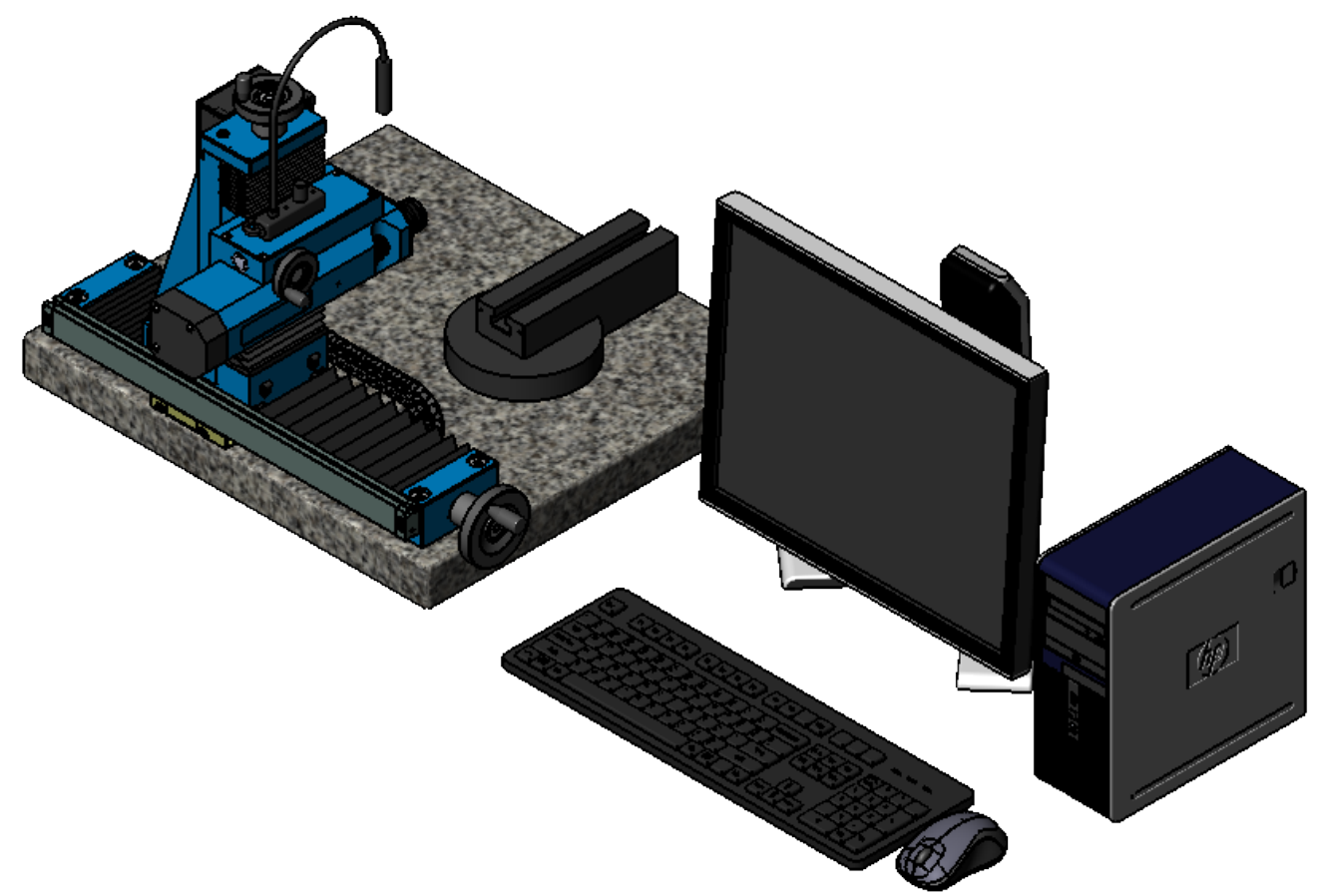
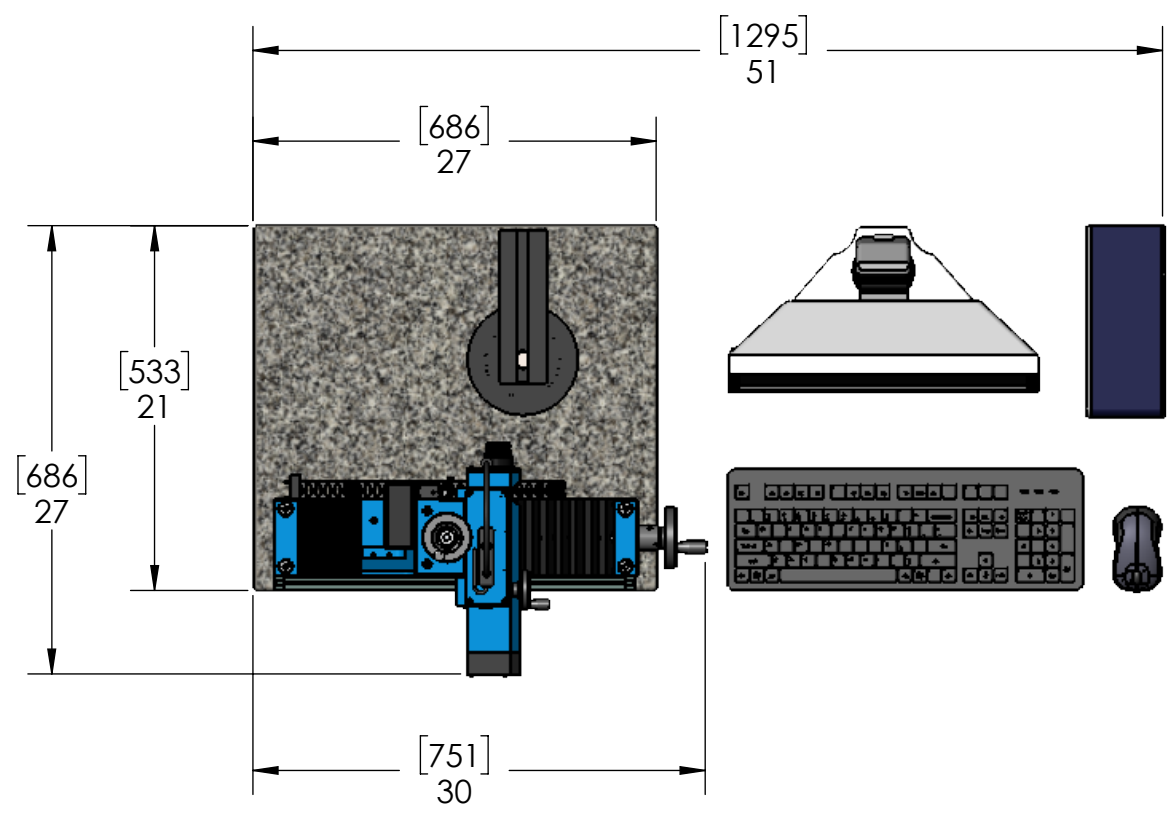

A

A

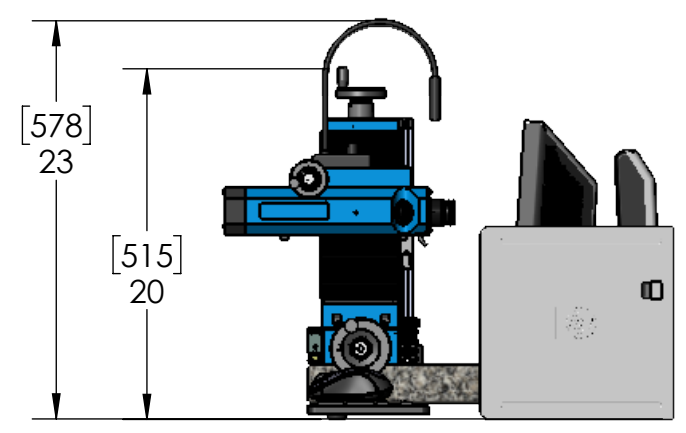
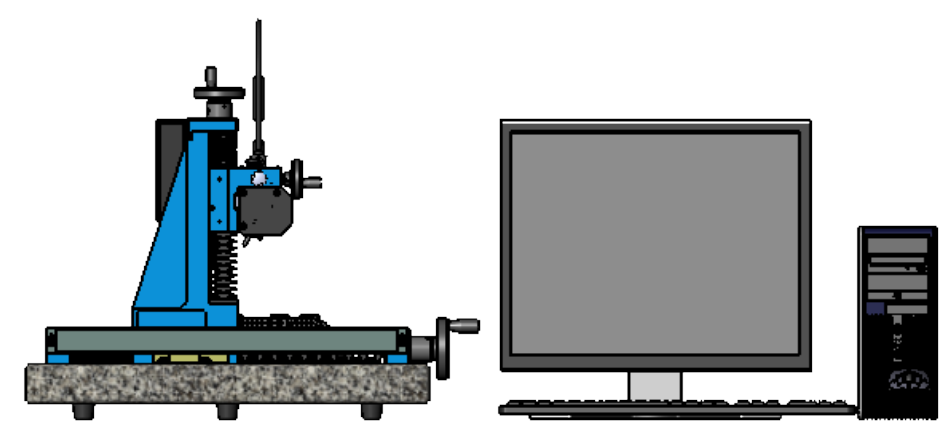

NOTES:
 1) DIMENSIONS ARE SHOWN IN INCHES AND [MM]
 2) 60"L x 30"D BENCH RECOMMENDED



THE PRODUCT IMAGES SHOWN ARE FOR ILLUSTRATION PURPOSES ONLY AND MAY NOT BE AN EXACT REPRESENTATION OF THE PRODUCT. PG INSPECTION RESERVES THE RIGHT TO CHANGE PRODUCT IMAGES AND SPECIFICATIONS AT ANY TIME WITHOUT NOTICE.

PROPRIETARY AND CONFIDENTIAL
 THE INFORMATION CONTAINED IN THIS DRAWING IS THE SOLE PROPERTY OF PG INSPECTION TECHNOLOGIES. ANY REPRODUCTION IN PART OR AS A WHOLE WITHOUT THE WRITTEN PERMISSION OF PG INSPECTION TECHNOLOGIES IS PROHIBITED.

DIMENSIONS ARE IN INCHES UNLESS OTHERWISE NOTED, TOLERANCES ARE: LINEAR DIMS. = ±.005 HOLE DIMS. = ±.003 ANGLES = ±.5°		DESCRIPTION: PG1000-400LT LAYOUT DWG	
USED IN ASSEMBLY		MATERIAL:	
SIZE B	DWG. NO. 400LT LAYOUT	REV A	
SCALE: 1:1	APPROX. WEIGHT:	SHEET 1 OF 1	

4

3

2

1